

# SupaBrake Universal kit installation:

There are two ways to do this. The quick and easy. Or the nice clean way.

Before making any of these mods please verify the function of the brake switches and tail light. Hook up the SBx kit in a temporary fashion and test its function prior to committing to the final installation.

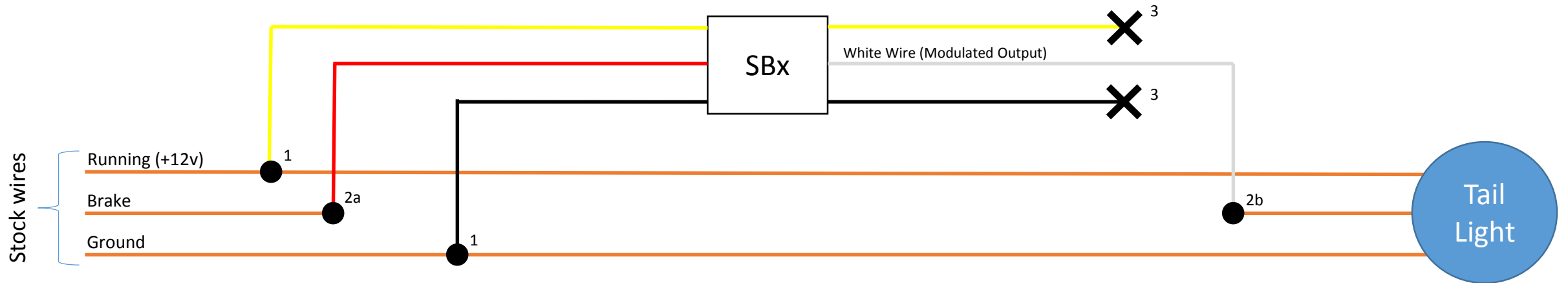

## Installation A: (quick and dirty)

1. Tap into the stock +12V and Ground wires of the stock wires. DO NOT CUT THESE WIRES. (Use included 2ea Posi-**Tap** connectors)
  - YELLOW will go to the +12V line of the bike.
  - BLACK will go to Ground.
2. Cut and open the stock brake line. (use included 2ea Posi-**Lock** connectors)
  - a) RED will go on the bike(harness) side.
  - b) WHITE will go to the tail light. Load side. This is what modulates your brake light.
3. Seal off the unused YELLOW and BLACK wire from the SBx. Use included tie-wraps to properly secure the wires and SBx.

Bonus: Note you can use the spare(unused) Yellow and Black wires from the SBx as a switched power source. The current limit will be dictated by the bike.(fuse or CANBus). From the SBx point of view, these are simple pass thru ;)

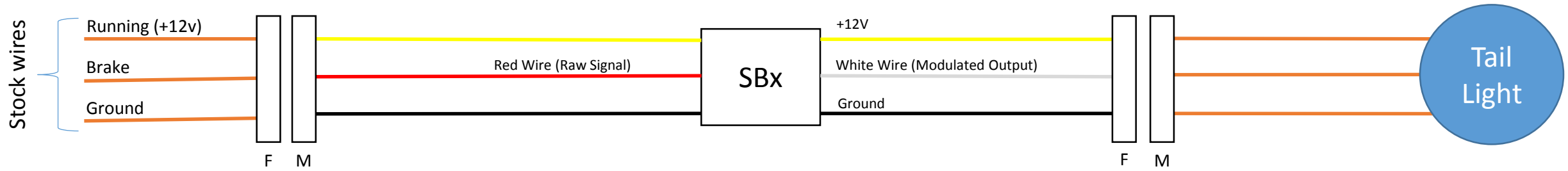

### Installation B: (clean way)

1. Order yourself the same OEM connectors that is on your bike or get two sets of good quality water resistant automobile grade connectors and hook them up as above. This will take a bit longer to install. But gives you option to remove the SBx kit and return bike to stock if/when you sell it. Note the male and female orientation of the connector. Allows to return bike in working condition without the SBx.

Use included tie-wraps to properly secure the wires and SBx.